

Please contact us if you require a CAD or 3D drawing

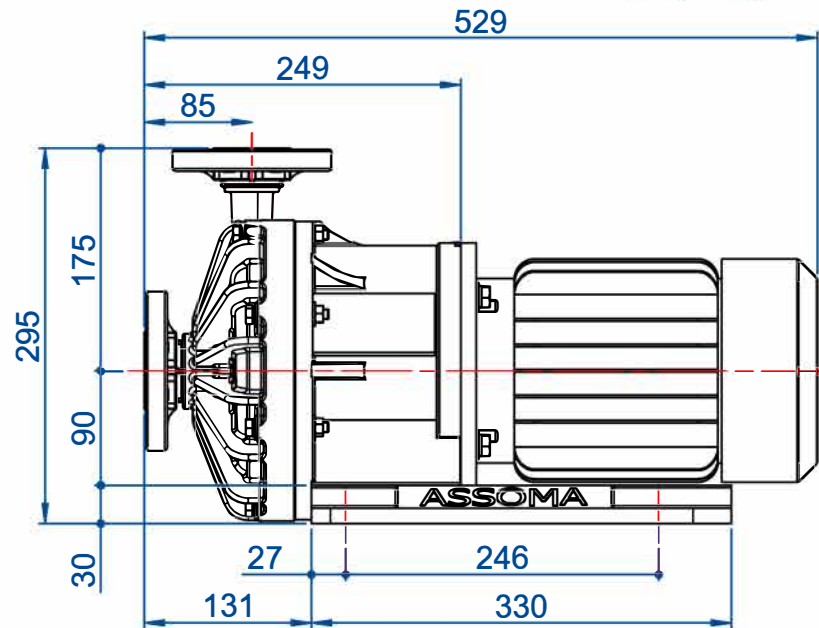
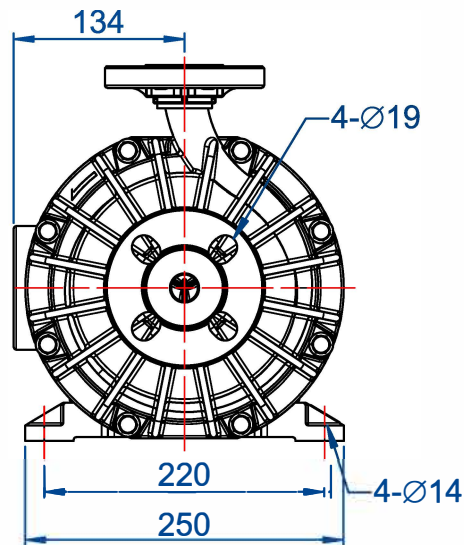
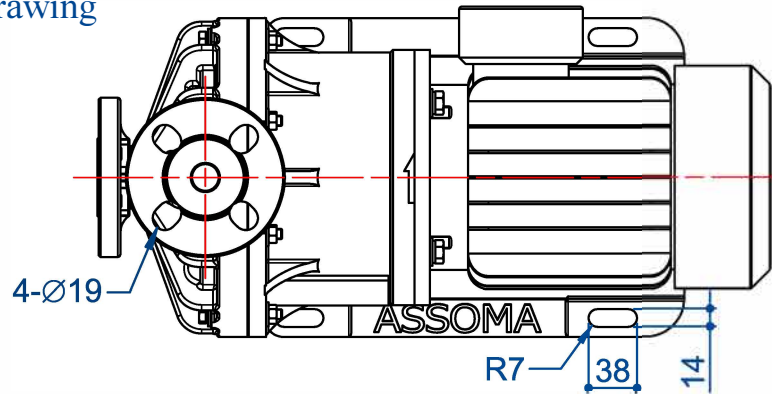

MOTOR	
Standard Code:	IEC
Frame:	90L Pole: 2
Output:	2.2 kW
Frequency:	50 / 60 Hz

FLANGE RATING	
Inlet & Outlet	ANSI 150lb x 1" x RF ( bore size 7/8" )
	DIN NP10 x 25 mm x RF ( bore size 22 mm )
	JIS 10K x 25 mm x RF ( bore size 22 mm )

Note: 1. All dimension in millimeter.

2. Tolerances of overall dimensions are according to DIN EN 735.

3. The total length & weight of the pump will differ depending on the brand of the motor.

Model \ Item	Pump (kg)	Motor (kg)	Net Wt. (kg)
AMX-223FG	9.7	22.0	31.7
AMX-223FE	10.6	22.0	32.6



MODEL

AMX-223F-VSGG

TITLE

OUTLINE DRAWING