

# CANTILEVER PUMP RANGE

VERTICAL, IMMERSIBLE, CENTRIFUGAL PUMPS



- ∞ CAPACITY <math><300\text{ M}^3/\text{HR}</math>
- ∞ HEAD <math><60</math> METRES
- ∞ RUN DRY DESIGN
- ∞ 0.3 - 1.5M COLUMN LENGTH
- ∞ SOLID PUMPING CAPABILITIES
- ∞ HEAVY DUTY - CANTILEVER SHAFT
- ∞ 316 STAINLESS STEEL CONSTRUCTION

Part of the  
**STAINLESS  
STEEL**  
Pump Range



HD-HG-RS



RD-RG-RC-RB



Vertical



Cantilever

## ∞ CANTILEVER OVERVIEW

The Cantilever range of vertical, immersible centrifugal pumps are built to be exceptionally resistant to harsh and corrosive applications, whilst manufactured to your exacting requirements. With column lengths from 300mm to 1500mm on a cantilever shaft without bearings or bushings, means complete reliability for your process as the pumps can be run dry without damage.

## ∞ FLEXIBILITY

We can tailor the pump to your exact requirements for both new and replacement applications with varying options of column length, materials of construction, impeller types, mounting plate size and discharge pipe location. The Cantilever range will be suitable for many various applications as they can be mounted internally or externally, suitable for temperatures <math><500^{\circ}\text{C}</math>, and pump clean or solids laden liquids.



**18 MONTHS  
WARRANTY**



**HIGH TEMPERATURE  
RESISTANCE**



**ENERGY  
SAVING**



**RUN DRY  
TECHNOLOGY**



**ISO2858 /  
EN25199**



**85% ENERGY  
EFFICIENT**



**SOLIDS  
PUMPING**



**STAINLESS STEEL VERTICAL IMMERSIBLE PUMPS**

Tel: +44 (0)1425 627700  
Email: [info@crestpumps.co.uk](mailto:info@crestpumps.co.uk)  
[www.crestpumps.co.uk](http://www.crestpumps.co.uk)

# CANTILEVER PUMP RANGE

VERTICAL, IMMERSIBLE, CENTRIFUGAL PUMPS

## ∞ PUMP RANGE CURVES

Pump curves for the Cantilever Stainless steel vertical pumps

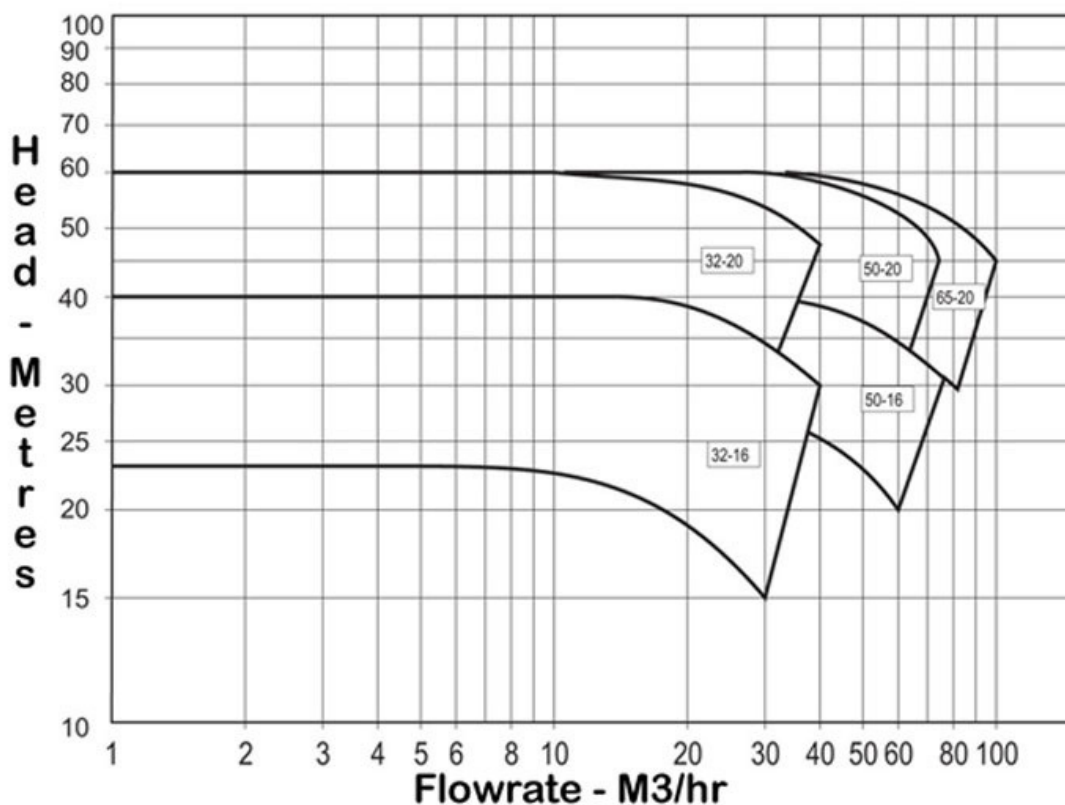

## ∞ TECHNICAL SPECIFICATION

MODEL	SUCTION / DISCHARGE (mm*mm)	SPEED (rpm)	RATED CAPACITY (m <sup>3</sup> /hr)	RATED HEAD (m)	MAX CAPACITY (m <sup>3</sup> /hr)	MAX HEAD (m)	MOTOR OUTPUT (Kw)	BEST EFFICIENCY (%)
50-32-160	50*32	2900	32	33	40	41	7.5	37
50-32-200	50*32	2900	36	51	40	63	15	35
65-50-160	65*50	2900	64	36	75	42	15	48
65-50-200	65*50	2900	58	52	75	60	18.5	46
65-50-250	65*50	1450	64	21	90	25	11	50
80-65-200	80*65	2900	78	52	100	60	22	51
100-80-200	100*80	1450	76	11	140	13	7.5	52
100-80-250	100*80	1450	120	24	150	27	15	57
100-80-310	100*80	1450	210	34	270	38	45	53
125-100-250	125*100	1450	190	21	250	22	22	54
150-125-250	150*125	1450	270	18	450	20	45	48
150-125-310	150*125	1450	320	32	400	37	55	54

# CANTILEVER PUMP RANGE

VERTICAL, IMMERSIBLE, CENTRIFUGAL PUMPS

## ∞ RANGE DIMENSIONS

For specific 3D CAD drawings or specific pump dimensions, please contact us at [info@crestpumps.co.uk](mailto:info@crestpumps.co.uk) or telephone +44 (0)1425 627700.

### NOTE:

1. The total length and weight of the pump will differ depending on the brand of the motor.
2. All dimensions are in mm.
3. Assembly tolerances are +/- 3mm.

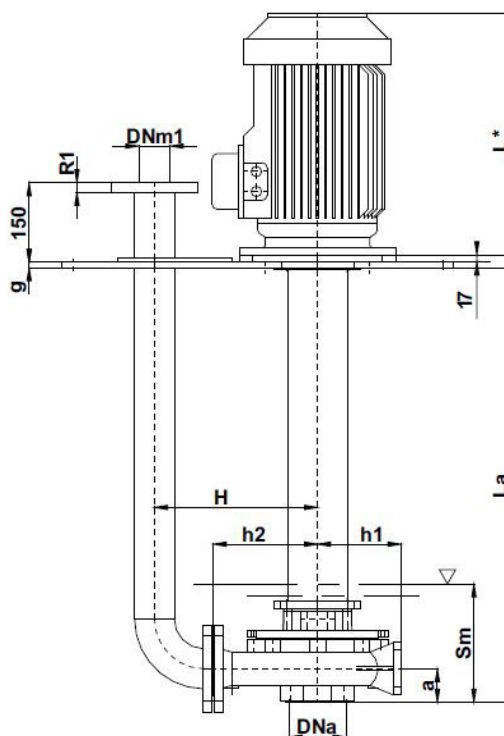
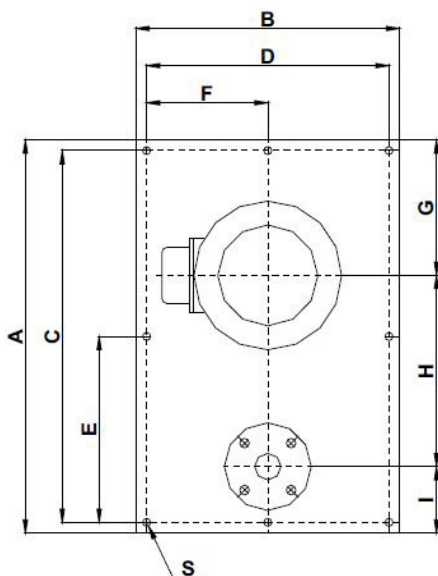

## ∞ DIMENSIONS TABLE

PUMP SIZE	DIMENSIONS (mm)																	
	PUMP							PLATE										
	DNa	DNm1	DNm2	a	h1	h2	Sm	A	B	C	D	E	F	G	H	I	S	g
50-32-160	50	40	32	48	132	160	168	740	500	700	460	350	230	255	235	252	15	10
50-32-200	50	40	32	48	160	180	174	740	500	700	460	350	230	255	255	232	15	10
65-50-160	65	65	50	55	160	180	184	740	500	700	460	350	230	255	294	192	15	10
65-50-200	65	65	50	55	160	200	182	740	500	700	460	350	230	255	314	172	15	10
65-50-250	65	65	50	55	180	225	190	990	600	940	550	470	275	320	339	332	19	12
80-65-200	80	80	65	65	180	225	208	990	600	940	550	470	275	320	359	311	19	12
100-80-200	100	100	80	70	180	250	218	990	600	940	550	470	275	320	422	246	19	12
100-80-200(S)	100	100	80	70	180	250	218	990	600	940	550	470	275	320	422	246	19	12
100-80-250	100	100	80	75	225	280	250	990	600	940	550	470	275	320	452	216	19	12
100-80-310	100	100	80	90	250	315	264	1190	830	1190	770	595	385	410	487	353	24	15
125-100-250	125	125	100	90	225	280	275	1190	830	1190	770	595	385	410	492	346	24	15
150-125-250	150	150	125	112	250	355	310	1190	830	1190	770	595	385	410	606	232	24	15
150-125-310	150	150	125	112	280	355	299	1190	830	1190	770	59	385	410	606	232	24	15

# CANTILEVER PUMP RANGE

VERTICAL, IMMERSIBLE, CENTRIFUGAL PUMPS

## ∞ INSTALLATION

A key feature of the Cantilever vertical pump range is the ability to pump liquids with temperatures up to  $<500^{\circ}\text{C}$  and the ability to run dry without causing damage to the pump, due to no bearings or bushings being submerged.

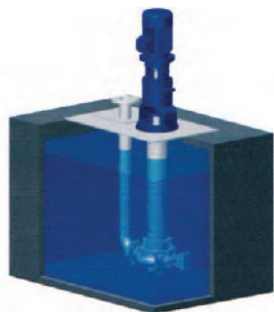

### Typical Installation

The pump can operate even without level controls and run dry if the tank empties. When the level rises again, the pump primes automatically and starts emptying, until the suction port is uncovered.

### Solid Pumping Capabilities

The pump can run without level controls and completely empty the sump/tank. Solids, floating or not, are removed when fitted with a vortex impeller (depending on size of pump).



### Extended Tail Pipe

The Cantilever range can be fitted with a suction extension to 5m. The pump can run dry until the liquid level reaches the impeller again. Once primed, the pump can empty the tank until the suction port is uncovered.

### High Temperature Resistance

Internal installation to the tank/sump allows temperatures up to  $500^{\circ}\text{C}$  with no mechanical seal, allowing the pump to run dry without causing damage.

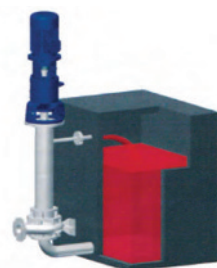

### External Installation

External installation to the tank/sump allows temperatures up to  $300^{\circ}\text{C}$  with a standard execution or can reach  $400^{\circ}\text{C}$  with a special execution, contact Crest for more details.

# CANTILEVER PUMP RANGE

VERTICAL, IMMERSIBLE, CENTRIFUGAL PUMPS

## ∞ CASE STUDY - MVV ENVIRONMENT

**“Generating usable power from a renewable source is an integral part of a new and sustainable energy supply. One way to produce environmentally friendly energy is using old and waste wood as fuel to generate electricity and usable heat”**



At Ridham Dock, MVV commissioned a highly modern and very efficient, combined heat and power (CHP) biomass power plant. CHP means the simultaneous production of electrical energy and usable heat. The heat energy from the CHP process is typically used in district heating systems and/or as process steam for industrial purposes. CHP uses a very high degree of the energy content of the fuel. The Ridham Dock plant, MVV will use about 172,000 tonnes of waste wood per year to generate almost 188 million kilowatt-hours of electrical energy. The plant has a net electrical capacity of 23 megawatts.

Crest Pumps provided its Cantilever pumps made from stainless steel construction - ensuring maximum corrosion resistance and capable of processing high temperature liquids at 85% efficiency. The pumps provided to MVV are manufactured with a vortex impeller, allowing for a high concentration of solid transfer.



## ∞ CREST STAINLESS STEEL VERTICAL IMMERSIBLE SVC PUMPS - UTILISED BY



## ∞ CANTILEVER PUMP APPLICATIONS



### CHEMICAL

The Cantilever range of Crest Pumps are fully corrosion resistant making the pumps ideal in a chemical environment.

Supporting high temperatures of over 500°C at high efficiency, this range can handle nearly all types of acidic applications, and is ATEX compliant.



### WATER TREATMENT

By allowing a high rate of solids to transfer through the Cantilever pump, makes it an extremely efficient option for the wastewater industry.

The vortex impeller allows for filamentous solid transfer and the design and mounting flexibility means this pump will fit efficiently in to your process.



### PHARMACEUTICAL

The Crest engineering team is mindful that the pharmaceutical industry requires pumps which are both reliable and efficient and can operate for long periods of time. The ability to transfer solids efficiently with various mounting options makes the Cantilever pump an ideal solution for this industry.



**STAINLESS STEEL VERTICAL IMMERSIBLE PUMPS**

Tel: +44 (0)1425 627700  
Email: [info@crestpumps.co.uk](mailto:info@crestpumps.co.uk)  
[www.crestpumps.co.uk](http://www.crestpumps.co.uk)